

CYCLING SPG

cycling supplementary planning guidance

reduce pollution
cycle routes
cycle lanes



Preface >>

Cycling is healthy and it is fun. It is also an efficient means of getting to work, to school, to the shops or to places of entertainment in a way that neither congests our streets nor pollutes our environment.

It is for all these reasons that Sandwell MBC is committed to encouraging, promoting and providing for cycling in the Borough.

However people will not “get on their bikes” unless they feel safe, are confident they can park their cycles securely, and have a direct and comfortable journey to where they wish to go.

This Supplementary Planning Guidance will play its part by ensuring that these conditions are met in all the many new developments that come forward every year.

I am grateful to all those who gave of their time and knowledge to the preparation of this document.
Happy Cycling!



Bob Badham
Cabinet Member for Environment and Transport

Acknowledgements >>

Cycling in Sandwell
Sandwell Primary Care Trusts
Tony Russell - Cycle Benchmarking Project

[Contents >>](#)



Contents >>

Section 1 : Introduction

click to navigate >>

About this Document	5
Expanding People's Opportunities	6
Good Health	8

Section 2 : Making Sandwell Cycle Friendly

Where We Want to Be	11
How We Get There	11
Guiding Principles	12

Section 3 : Designing for Cyclists

Basic Considerations	15
Hierarchy of Measures	17
Checklists	20
Planning and other Agreements	25

Section 4 : Measures

On Highway Measures	27
Off Road Cycle Routes	48

Section 5 : Standards for Parking and Storage

Cycle Parking Standards	53
Cycle Parking – Location and Design	55
Secure Cycle Parking	59

Appendices

1	Glossary	61
2	Useful Contacts	63
3	Other Documents	64

List of Figures

Figure 1	Overweight children aged around 10 years compared to levels of cycling in selected countries	8
Figure 2	UK cyclists deaths compared to deaths attributable to inactivity	9
Figure 3	European and UK levels of cycling and car ownership	11
Figure 4	Cyclists dimensions and space requirements	16
Figure 5	Possible cycle facilities related to vehicle flow and speed (CROW monogram)	17
Figure 6	Widths of Cycle Lanes	18

Diagrams

Standard detail Traffic Speed Cushion	30
Standard detail Flat Top Road Hump	31
Sinusoidal Road Hump	32
Speed Table	34
Modified Roundabout	41
Mandatory Contra Flow Cycle Lane	43
Advisory Contra Flow Cycle Lane	44
False One-Way Street	45
Off road Cycle Route Specification	50
Sheffield Stand	56
Penny Farthing Stand	57

[Contents >>](#)

About this document

- 1.1 Supplementary Planning Guidance (SPG) can provide additional, more detailed advice on planning policy to anyone intending to make a planning application or developing a proposal. It is a material consideration when determining planning applications, and therefore it will be expected that proposals will reflect the contents of such guidance. This SPG can also be used for the review of cycle provision within existing developments.
- 1.2 This Guidance builds on the policies contained in the Unitary Development Plan (UDP). UDP Policy T1 adopts a priority for movement to provide choice and the provision of access for all of the community, which places cyclists high on the order of consideration. Policy T7 addresses the development of a network of cycle routes. Policy T18 is also important for the provision of cycle routes. In addition, for the first time, a network of cycle routes is indicated on the Proposals Map. The network is also to be found on the Sandwell Cycle Route Map
- 1.3 This SPG on cycling also takes forward the Government's desire for cycling to be catered for and to grow. The Local Transport Plan for the West Midlands includes a target to double the number of journeys made by bicycle by the end of 2031, with interim targets of 3% of all journeys by 2006 and 4% by 2011.
- 1.4 This Guidance is aimed at everyone involved in the development process.

including;

employers/managers

developers

architects

agents/master planners

development control officers and highway engineers

[Contents >>](#)



1.5 **Section 2** - Discusses the guiding principles which should underpin the design of schemes involving cycling provision.

1.6 **Section 3** - Indicates some basic considerations when designing for cyclists, the hierarchy of measure available, how to find an appropriate approach, and the use of planning agreements. There are also checklists designed to aid the proper consideration of cycling by all participants.

1.7 **Section 4** - Provides a 'tool box' of detailed measures which are considered to be successful responses to particular circumstances.

1.8 **Section 5** - Gives standards for the number, specification, design and location of cycle parking/storage.

Expanding People's Opportunities

1.9 It's all too easy to wrongly assume that we are now all dependent on cars. Rush hour sees two thirds of commuters crowding the streets with their cars. As a result they have tended to dominate the attention of councils and transport planners, attracting a disproportionate amount of spending remedying the problems that they cause. The reality is however that there is still only a minority of people who can actually afford cars and are capable of driving them. In Sandwell 43,261 households do not own a car. For the 72,165 households that do, the use of the car is usually the preserve of one person in the household. So it's easy to overlook the fact that at least 150,000 people – more than half the population of the Borough - want or need to travel each day but cannot use a car.



- 1.10 Non-drivers and those without access to a car are in the majority and being less mobile their social, job, shopping and leisure opportunities are more limited by comparison. However Sandwell has six Towns and a diverse land use pattern which places most things within a relatively short distance of each other. Potentially it should be ideal for walking and cycling, however the amount and mix of traffic and congestion conspire against this.
- 1.11 If cycling could be made more appealing it would significantly expand the possibilities for tens of thousands of non-car drivers and give a healthier alternative for those who are currently driving. Bicycles are comparatively cheap and appeal to many people, which probably explains why there are more bikes bought than cars each year. It is estimated that half of Sandwell's households own one or more bikes and their owners do have the ability to ride them. So with three out of every four journeys made in Sandwell by Sandwell residents being less than a twenty minute cycle ride, quite a significant proportion could be done by bicycle.

A recent survey of a major employer* in Sandwell showed that many of its work force live within easy cycling distance of their place of work (6 miles). A considerable number of employees also expressed a wish to cycle to work, but the chief reasons given for not doing so were;

- Danger from traffic
- Lack of changing/washing facilities
- Lack of secure parking
- The need to use their car for work purposes

source: *Sandwell Health Authority 2002

[Contents >>](#)



Good Health

1.12 The death rate from coronary heart disease in Sandwell is about 16% above the national average. 37% of these deaths are attributable to physical inactivity. Put simply this means that's some 125 people in Sandwell die prematurely from heart attacks each year due to lack of exercise. To maintain a healthy heart, adults need to do at least 30 minutes of "moderate exercise" on five days of each week. "Moderate exercise" in practice means something that just raises the heart rate a little, like brisk walking or gentle cycling. It is reckoned that fewer than 30% of people, both young and old in England, achieve this amount. Sandwell is no exception as, based on these figures, some 200,000 people are not getting enough exercise to avoid health problems.



1.13 Cycling to work or school is an excellent and useful way of getting the regular exercise that is required. A 20 minute journey (3 to 4 miles for most people) twice a day is enough. At this rate it burns off about 200 to 400 calories per day. Evidence shows that people who exercise in this way are more likely to sustain this behaviour out of habit, compared to those that deliberately find time out of their daily routine to go training or exercise for health alone (e.g. by going to a gym, playing squash, jogging, etc.).

figure 1

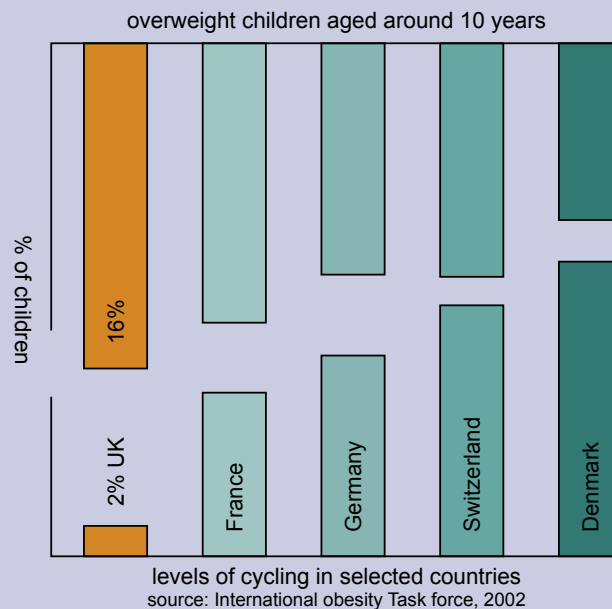
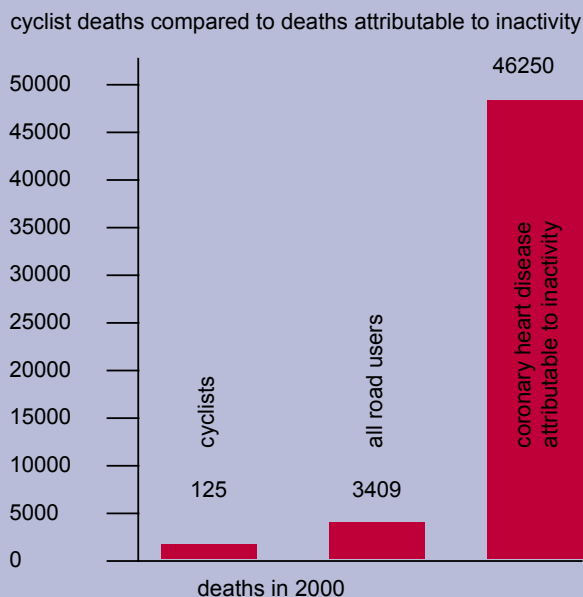

figure 2



- 1.14 Cycling is also kind to joints as it is a non-weight bearing exercise. Like most forms of physical activity, it can have a wide range of other benefits to health: it helps to prevent or control diabetes, obesity, strokes, high blood pressure, blood cholesterol levels, asthma, certain cancers, stress, depression and arthritis. It also helps develop muscle strength and prevent falls in the elderly.
- 1.15 The costs of implementing cycle measures are likely to be more than recouped through savings in health expenditure.
- 1.16 For local residents who do not cycle, there are the physical and mental health benefits that comes from more people travelling through their neighbourhood using silent, zero polluting vehicles.



2 Making Sandwell Cycle Friendly >>

Where We Want To Be

- 2.1 Sandwell should be a Borough where cycling is an everyday activity, where cycling is a common means of carrying out short journeys, whether they are for accessing employment, leisure, goods or services.

How We Get There

- 2.2 The cycling environment has not simply appeared. It has come about as a result of many decisions made by those with an influence on it. The Unitary Development Plan is clear that decisions for cyclists need to be integral to the design process, and not as an afterthought. Designers need to think about cycling and gain experience of good and bad practice.

European Levels of Cycling

Despite their having a similar number of cars as the UK, people in continental countries cycle over seven times as far.

figure 3

number of cars per thousand population



Average number of miles cycled per week

[cycle routes](#)

[Contents >>](#)



Guiding Principles

- 2.3 The Guiding Principles to creating a useful cycle network served by facilities for cyclists are outlined in Policy T7 of the Unitary Development Plan. This recognises that there are 5 criteria which make up the requirements of good cycling infrastructure. These are:

Coherence

- 2.4 Easy-to-follow cycle routes should offer cyclists continuous links to all of the important destinations within Sandwell and in the neighbouring boroughs. The 100km 'Network of Safer Cycle Routes' is Sandwell's initial solution to provide a core network. This is recognised by the routes being included as proposals in the Unitary Development Plan. These routes complement the existing network of quieter residential roads which provide valuable facilities for cyclists. Coherence is given by using them to link together the Borough's centres and significant areas of employment. Routes need to be signed and therefore easily read and followed by cyclists. This legibility can be further enhanced by ensuring that the route is provided to a consistent standard.

Directness

- 2.5 Routes serve a purpose and should be as direct as possible between destinations, based on where cyclists instinctively want to go (desire lines). Detours away from these desire lines and imposition of unnecessary delays will deter cyclists.

Attractiveness

- 2.6 Cycling has to be enjoyable, providing interest and a sense of getting somewhere. The perception of the route by the cyclist is very important. Threading the routes through and integrating them with surroundings that are varied and at a human scale, with plenty of identifiable landmarks and staging points, all helps to enhance the experience. Noise, other users, lighting, and aesthetics are all important. Wherever possible a route should complement and enhance the area through which it passes.



[Contents >>](#)



A

B

Safety

- 2.7 Designs should minimise casualties and perceived danger for cyclists and other users. In a 1992 Survey of 676 Sandwell Health Authority staff, two out of three said they would not cycle because of 'danger from other traffic'. It remains by far the biggest deterrent. More recently, in 2002, a report by a leading transport consultant indicated that in the West Midlands it is the speed and closeness of traffic which is the main concern. Good design is therefore essential in helping to overcome this perceived and actual danger. Reducing the intimidation for cyclists from fast moving motor vehicles passing close by is vital. Removing any uncertainty in the minds of cyclists, drivers and pedestrians that could lead to accidents is also important. Above all, good design should emphasise the need for all road users to be aware of each other and take care.
- 2.8 The same survey revealed that one in seven were afraid of being attacked. Fear of crime can be more debilitating than actual crime itself. Clearly cyclists are riding on an expensive item of equipment which can be easily stolen and they are probably carrying money and other valuable possessions. Cyclists as potential targets need to be protected and reassured. So it's wise to create a cycle network with routes that avoid isolating lone cyclists away from the surveillance of other people and by places where potential attackers can hide. The Community Safety SPG gives further guidance on designing for personal safety. All cycle schemes should be subject to an Institute of Highways and Transportation cycle audit.



credit: Jez Coulson/Insight

Comfort

- 2.9 Cyclists need smooth, well-maintained, regularly swept surfaces, with gentle gradients and flush kerbs. Raised drain and manhole covers should be avoided as should complicated manoeuvres and interruptions to progress. Some shelter from strong winds is desirable.

TOP TIPS for cycle helmets

GOOD FIT	POOR FIT
tight straps	loose straps
helmet level	helmet pushed up
straps on either side of ears	straps over ears

[Contents >>](#)

2.10 In addition, cyclists also need:

Good Facilities on arrival

- 2.11 Cyclists need to feel confident that at their destination there is secure parking for their bikes. Sadly as many as one in three of the health staff surveyed in 1992 said they were worried about their bike being stolen when parked at work. This level of concern is borne out by official police statistics which record some 400 bikes being stolen from public places in Sandwell each year – the unrecorded numbers are undoubtedly much higher than this.
- 2.12 In addition, cyclists would benefit from the opportunity to change and to shower at their destinations. This would encourage more people to cycle and to help overcome their concerns about the weather, which prevents many from cycling.



[Contents >>](#)



Basic Considerations

- 3.1 There are many types of cyclist with different ages, abilities, attitudes and reasons for cycling. They therefore have a variety of needs that should be recognised and catered for. A core of confident riders are prepared to mix with busy traffic. However the vast majority are discouraged by motor traffic and will seek quiet streets and off road routes. It is these cyclists who should be planned for as they would benefit most from extra measures that overcome their concerns and help them build up their confidence.
- 3.2 Before looking at specific measures and solutions to assist cycling, the cyclist needs to be considered. He/she has to drive, power and balance their vehicle simultaneously. This is a unique combination of skills and it gives designing for the bicycle its special characteristics. The main issues that must be taken into account when designing infrastructure which is cycle friendly are:
- 3.3 The bicycle is a vehicle. When designing for cyclists an approach similar to that for designing for motor traffic must be used. Thus criteria such as surface, sightlines, minimum radii for curves on corners, turns and changes of direction, width and design speed must be carefully considered.
- 3.4 Bicycles are muscle powered, even battery motor assisted cycles primarily rely on human muscles for the majority of the journey. Cycle friendly design should therefore aim to minimise energy losses. The most frequent causes of energy loss are stopping, hills and sharp corners. In addition the regular cyclist generally wants the shortest most direct route between origin and destination. Cyclists should not be required to dismount on cycle routes unless absolutely necessary. Because cycles are human powered their individual speed is to a large extent a function of the fitness of the rider. Their speed varies considerably, but it must be remembered that a regular cyclist can ride fast. A design does not necessarily have to have specific provision for cyclists to be cycle friendly (and vice versa).

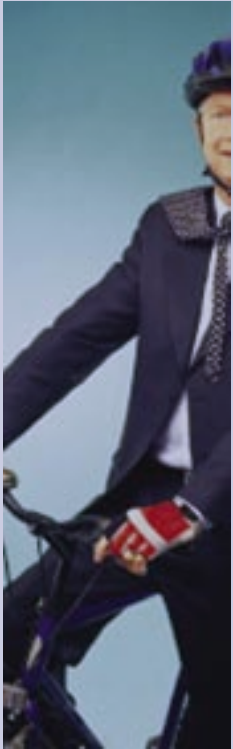

3.5 Bicycles have no crumple zones! The cyclist is vulnerable and this is obvious from the accident statistics. Their potential speed adds to their vulnerability. Many specific provisions for cyclists, such as cycle lanes, Advanced Stop Lines, segregation and off road cycle tracks, aim to separate cyclists from sources of danger.

3.6 The cyclist occupies a surprisingly large area. A typical adult's bicycle is approximately 1.8m long and 0.6m wide. Tandems, tricycles, recumbents and cycles with trailers are larger, approximately 2.7m long and 0.7m wide. In addition to elbow width of about 0.75m, a cyclist needs manoeuvring space (deviation margins) of approximately 0.25m as it is not possible to cycle in a perfectly straight line. Furthermore a margin of about 0.5m is required for safety and comfort. See Figure 3 below. It should also be realised that cyclists ride at least 0.6m from the kerb on any road and if the kerb area has yellow lining, multiple drain grills and/or a poorly maintained surface then this distance will be increased.

3.7 Both adults and children cycle Encouragement of bicycle use by children is important to increasing the role of cycling as a means of transport. Child cyclists put safety and enjoyment first and are unable to cope with speed. It is important to develop a balanced network of routes and give opportunities for all.



Figure 4 - Cyclists dimensions and space requirements

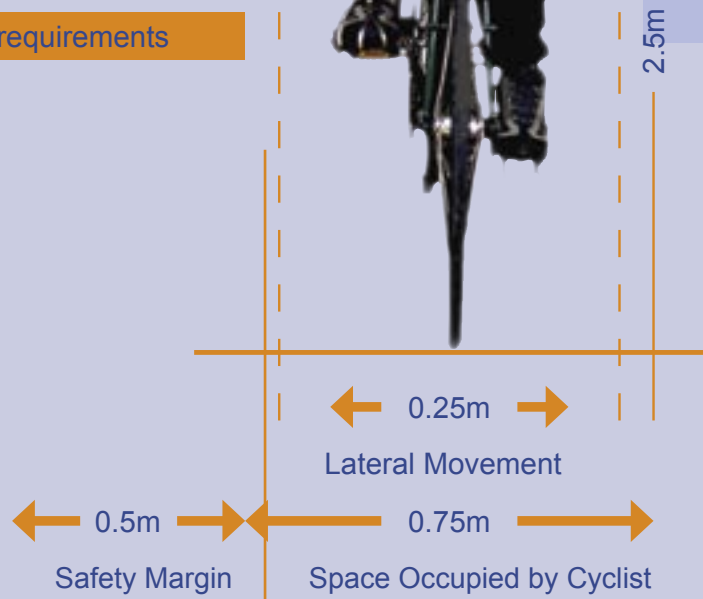

Hierarchy of Measures

3.8 There is no single correct way to provide for cyclists. Many features of the highway infrastructure, its function and the way in which it is used have the potential to be altered, depending on the approach adopted, and the intended users. Different measures are therefore appropriate in different circumstances. Possible cycle facilities related to vehicle flow and speed are shown in Fig 5.

figure 5

Possible cycle facilities related to vehicle flow and speed (CROW nomogram)

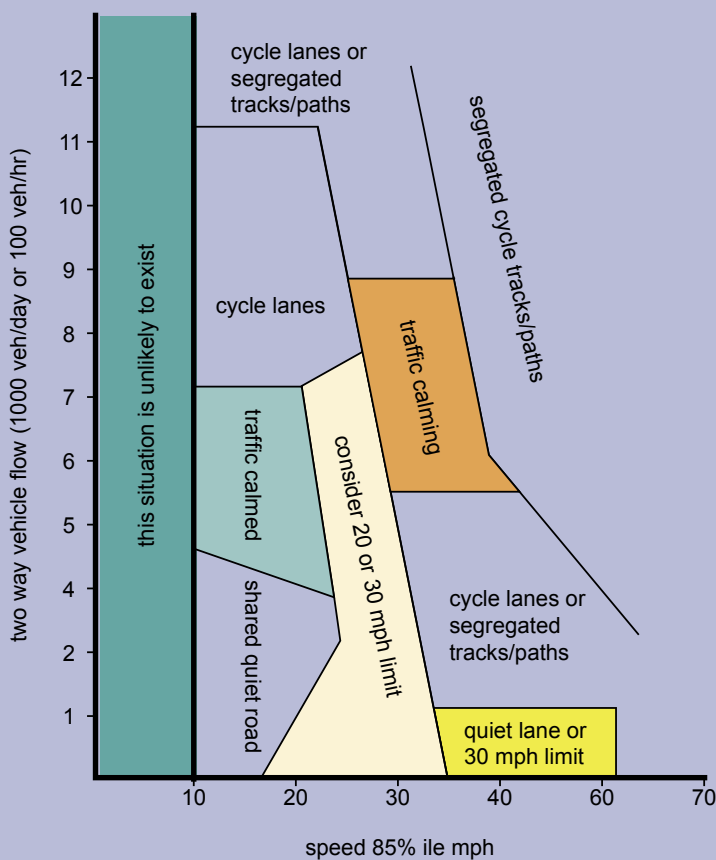

Nb the speeds referred to are not the speed limits of roads, rather they are 85% of the maximum recorded speed.

[Contents >>](#)

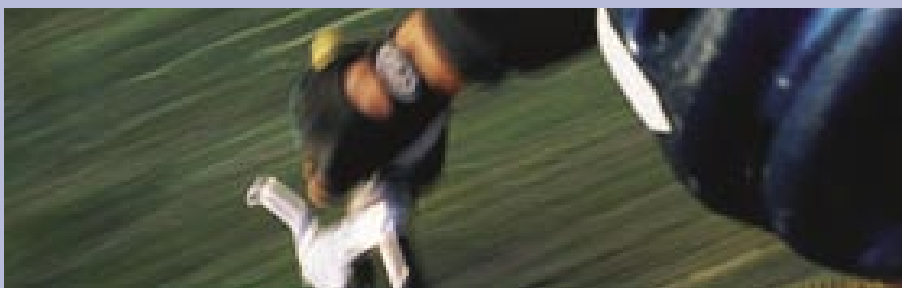

figure 6

Widths for Cycle Lanes

For high flow/low speed zones where cycle lanes are recommended (two zones on nomogram) (Figure 4)

Advisory cycle lanes		Mandatory cycle lanes	
Gradient	Minimum width (m)	Gradient	Minimum width (m)
Uphill	1.2	Uphill	1.3
Level	1.1	Level	1.2
Downhill	1.5	Downhill	1.5

For low flow/high speed zones where cycle lanes recommended (one Zone on nomogram)

Advisory cycle lanes		Mandatory cycle lanes	
Gradient	Minimum* width (m)	Gradient	Minimum width (m)
Uphill	1.3	Uphill	1.5
Level	1.2	Level	1.4
Downhill	1.5	Downhill	1.5

Ideally on dual carriageways which are suitable for experienced cyclists, consideration should be given to maximising the width of the inside running lane. This would enable motor vehicles to overtake cyclists without encroaching into the outside lane.



3.9 The following hierarchy of measures should be used:

Traffic reduction.

Can traffic volumes be reduced sufficiently to achieve the desired improvements in attractiveness and safety for cyclists? In particular, can heavy lorries be restricted or diverted?

Speed reduction.

Can motor vehicle speeds be reduced and driver behaviour modified to achieve the desired improvements?

Junction treatment and traffic management.

Can problems that cyclists encounter, particularly large roundabouts and accident locations, be treated by specific junction treatment or other traffic management solutions such as contra-flow cycle lanes and cycle-slips?

Redistribution of the carriageway.

Can the carriageway be redistributed to give more space to cyclists, do opportunities exist for improvements in conjunction with buses?

Off-Carriageway segregated provision.

Having considered and where possible implemented the above, where these are considered as the only satisfactory answer then segregated cycle facilities should be provided.

Off-Carriageway shared provision.

Shared use facilities will only be approved where there is absolutely nothing else which can be done.

Nb Cycle access between the carriageway and segregated or shared use routes should be facilitated by a smooth, easily seen transition.



top>bottom

Traffic lanes narrowed to reduce speeds and number of lanes.

Speed reduction by pedestrian refuge and parking bays.

Bus and cycle lane.

left > right

Segregated route putting cyclist on the pavement.

Segregated route past a bus stop.

Segregated route allowing access to toucan crossing.



Checklists

3.10 In order that those involved in developments can properly consider and provide for the needs of cyclists, the following checklists have been developed. These are designed to provide a straightforward, structured and comprehensive series of questions which, when followed, will enable the range of issues to be addressed.



[Contents >>](#)

Developer /Architect/Masterplanner Checklist

General

- Consider the needs of cyclists at an early stage in the process
- Provide for the needs of the cyclist as a priority above that of the private car
- Ensure the proposal encourages the use of the cycle
- Is there a need for a Transport Assessment?
- Provide a Travel Plan
- Consult users/officers of the Council/local cycle organisations

Cycle Route Issues

- Where is the proposal in relation to the existing Cycle Network as defined by the UDP and indicated on the Sandwell Cycle Route Map?
- Where is the proposal in relation to a cycle route to schools, shops, leisure and places of work?
- How does the proposal contribute to or access the above?
- Is new provision for cyclists required?

On Site Issues

- How does the proposal achieve the Guiding Principles? (see pages 12-14)
- Has the appropriate approach been provided? (FIG 5 page 17)
- What engineering measure is appropriate? (see section 4)
- How has cycle storage/parking been provided? Is it of the appropriate type properly located and sufficient in number? (see page 53-60)
- Have other facilities been provided to ensure cycling is a genuine choice? e.g. showers, changing rooms/ lockers

Off Site Issues

- How does the proposal contribute to off site cycle infrastructure? (see page 25)
- How does the proposal contribute to other means of encouraging cycling? eg local cycle schemes/ projects, training, information
- How does the proposal provide for facilities to help cyclists combine their trips with other forms of transport? (bus, train, tram etc)

Development Control Checklist

General

- Has cycling been considered from the outset and given due priority?
- Is there a need for a Transport Assessment?
- Should there be a Travel Plan?
- Does the application indicate how cycling will be facilitated or is there a need to ask for additional information?
- Is there a need for a cycle audit?
- Have the appropriate persons been consulted?
Internal - Cycling Officer, Engineers
External - is there a need to consult a local cycle group?

Cycle Route Issues

- Does the proposal lie on or adjacent to a cycle network as defined by the UDP, if so does it prejudice or contribute to the route?
- Does the proposal have the potential to contribute to a safe route to schools, shops, leisure, and places of work?
- Is the proposal accessible from/to the above?
- Does the proposal prejudice future cycle route provision?

On Site Issues

- Is access and circulation by cycle provided for?
- Is it appropriate? (see Guiding Principles pages 12-14)
- Is the storage/parking of cycles provided, for is appropriate, well located and sufficient? (see page 53-60)
- Are there other facilities necessary to encourage cycling, e.g. showers, changing facilities?

Off Site Issues

- Should there be a contribution to off site cycle infrastructure? (see page 25)
- Does the proposal encourage cycling in other ways, e.g. contribution to local cycle schemes, training, information
- Does the proposal provide facilities which help cyclists combine their trips with other forms of transport (bus, train, tram etc)

Employers/Managers Checklist

General

- Recognise the mutual health, environmental and economic benefits of cycling and ensure your work force has the necessary facilities and information to encourage and enable them to cycle
- Consider the needs of cyclists as an essential element in the early design stage of your new development or additions/changes to your premises.
- Consult work force on their requirements
- Consult the Council's Travel Plan Officer (see contacts list)

Cycle Route Issues

- Ensure that the proposal contributes to or gives access to;

a cycle route as defined in the UDP,
a cycle route to schools, shops, leisure and places of work.

On Site Issues

- Ensure that your premises will provide for good bicycle access and to cycle facilities
- Ensure your premises will provide sufficient safe and secure cycle storage/parking for your workforce and visitors in an appropriate location and in the correct number (see page 53-60)
- Ensure your premises will provide adequate facilities for your workforce to change, wash and store clothes and/or baggage.

Off Site Issues

- Ensure your premises provide good access to cycle facilities adjoining the site
- Examine how you can contribute to other means of facilitating cycling, e.g. training, information etc

Traffic Engineer Checklist

General

- Provide for the needs of cycling early in the design process and give priority to the cycle above that of the private car
- Ensure the fullest use of appropriate engineering measures to assist cycling
- Carry out a cycle audit on every scheme
- Consult users/local cycle groups/cycling officer

Cycle Route Issues

- Ensure the proposal contributes to any nearby cycle route as defined by the UDP
- Ensure the proposal contributes to a safe cycle route to schools, shops, leisure and places of work.
- Ensure the scheme provides access to the above

On Site Issues

- Ensure the scheme implements the Guiding Principles (see page 12-14)
- Ensure the measures chosen are appropriate to the circumstances
- Ensure the scheme contributes to the integration of cycling with other forms of transport

Off Site Issues

- Ensure the scheme links/integrates with cycling provision adjoining the scheme.

Planning and other Agreements

- 3.11 Most developments, except for small extensions, domestic alterations etc., will normally be required to provide for cycling, usually directly through on site provision and/or where appropriate off site infrastructure.
- 3.12 Contributions to, or provision of, off site infrastructure facilities and their maintenance may be subject to agreements or undertakings, particularly 'Section 106' agreements. Where the latter are used, the agreement will be consistent the contents of Circular 1/97.
- 3.13 Circumstances where such off site provision will be required include;
- where a development creates the need for cycle provision off site where such need did not exist beforehand
 - where a development exacerbates the need for cycle provision off site where currently there is no provision
 - where a development creates sufficient additional need to require the upgrading of existing provision
- 3.14 Off site provision may take the form of;
- highway measures (see measures pages 27-48), e.g. junction treatment, cycle lanes, slips, traffic calming etc.
 - Links to the cycle network
 - Creating sections of the cycle network
 - Cycle parking/storage (see page 53-60)
- 3.15 A Section 106 agreement may also involve the preparation of a Travel Plan, possibly through the Company Travel Wise initiative. This would be required to address, along with other alternatives to the private car, the encouragement and enabling of cycling. More details on these are available from the Council's Travel Planning Officer on 0121 569 4261.



- 4.1 The following provide examples of a range of measures for the cyclist in various circumstances. It is not an exhaustive list and other ways may be found which provide adequately for cycling, but generally it is a useful 'tool box' of technical solutions to commonly occurring situations.

On Highway Measures

Cycle slips

- 4.2 Junctions present the most hazards to cyclists and multi lane approaches to large roundabouts are particularly difficult. Cycle slips can help in these situations creating a safer path for cyclists. The practicality of keeping these features swept by mechanical means needs to be considered at the design stage.



top left > top right >

Separate traffic signal for cyclists with signals timed to let cyclists go before other traffic.



Cycle slip allowing cyclist to turn into side road and re-enter carriageway in a protected position.



Cycle lane for cyclists allowing them to bypass roundabout and get ahead of traffic.

[Contents >>](#)



left >

Examples of build-outs which force cyclist to weave out into the traffic or be pinched by cars creating a dangerous situation. Where these are installed road markings, hatching and signage must be installed.

Poorly positioned cycle bypass is obstructed by residents cars.

right >

Cycle bypass through chicane.

Road closure with cycle slips.

Chicanes

4.3 Chicanes are an important traffic calming measure which reduce speeds and therefore make cycling easier and more attractive. However they need to be carefully designed so the cyclists are not forced out into the traffic or squeezed by vehicles as they move back into the side of the carriageway after going through the chicane. The best way of overcoming this problem is for a cycle slip to be incorporated into the design.

Cycle bypass

4.4 Cycle bypasses can be of great benefit to cyclists in protecting them and creating a feeling of safety. They allow a direct route for cyclists, ideally on the desire line of travel.

Speed Cushions

- 4.5 Speed Cushions are recommended as a means of slowing traffic and calming roads. They sit out in the carriageway and allow cyclists to pass on the level surface adjacent to the kerb. This gap should be wide enough to allow free passage by cyclists and also allow for cleaning. This means that the minimum gap should be 0.75m between the base of the cushion and the kerb (although 1.0m is the ideal width as stated in the DOT 1994 TAL 4/94). Details of speed cushions are shown in the drawings on page 30.

Road Humps

- 4.6 Road Humps raise the surface of the road by between 25mm and 75mm in order to reduce the speed of vehicles. They can only be constructed on roads with speeds limits of 30 mph or less. Their use is generally discouraged and alternatives such as speed cushions and speed tables need to be considered first. Where a cycle bypass is not possible, abrupt changes of gradient can disrupt the smooth passage of cyclists. Humps should be surfaced in the same material across the whole hump. The previous construction incorporating kerbs has created problems for cyclists and also for the maintenance of the hump. Some road humps can be sited on wide carriageways with a bypass for cycles around the hump using either a mandatory or advisory cycle lane. These bypasses can have a protection island or not. However where no island is provided then the issue of the likelihood of obstruction by parked vehicles needs to be assessed.
- 4.7 The leading and trailing gradients for ramps should be specified to avoid jarring cycles. It is therefore recommended where there are substantial cycle flows already or such are to be promoted then consideration is given to using a sinusoidal road hump, although this would require specific approval from the Department for Transport. Details of hump designs are shown on drawings on pages 31-32.

Standard Detail Traffic Speed Cushion >>

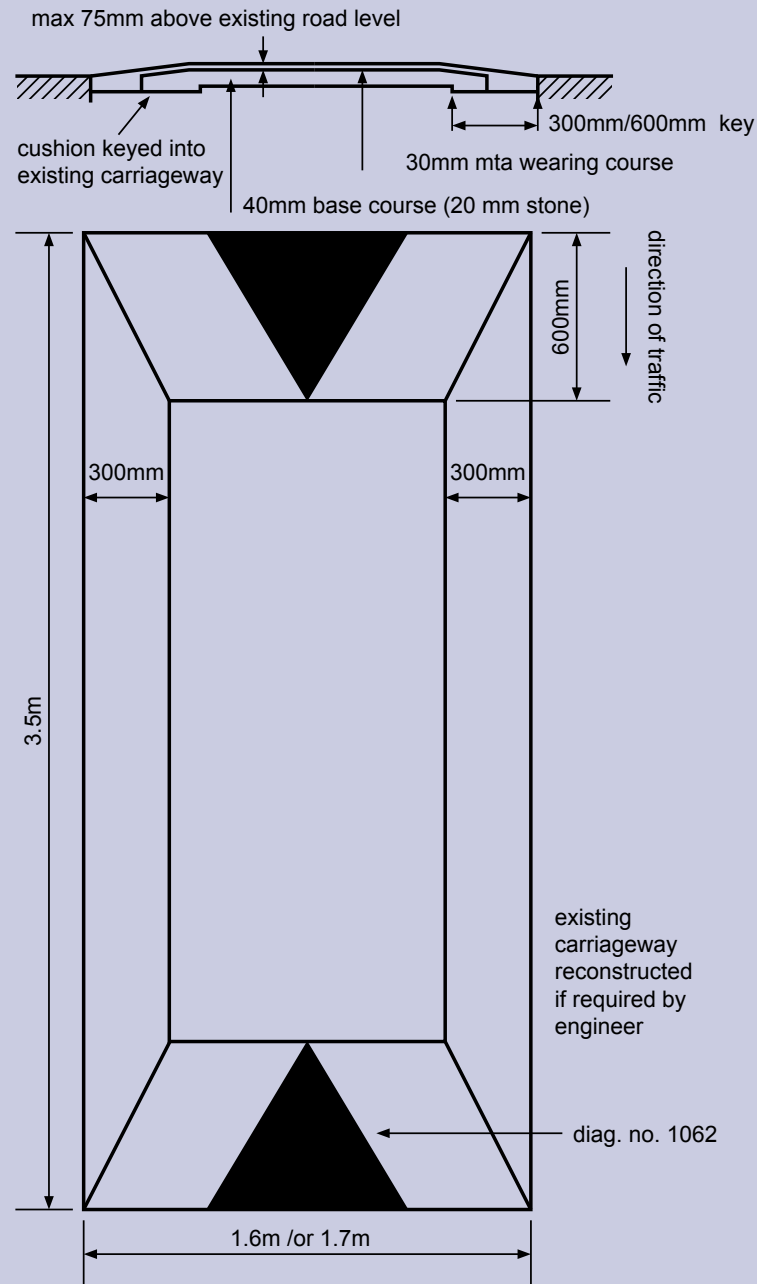

1	The contractor must ensure that the cushion does not exceed 75mm above the adjacent carriageway surface
2	Where cushions are installed 3 a breast triangular road markings are required on both gradients of the central cushion.
3	Width to be 1.6m or .7m. see relevant setting out, pavement and drainage drawings.
4	All road marking to be in accordance with 'the traffic signs regulations and general directions 2002'.

Contents >>

Sinusoidal Road Hump >>

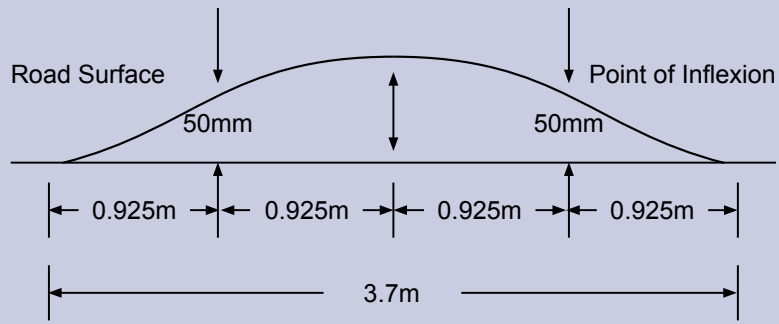

cross section of proposed sinusoidal road hump with tapered edges (not to scale)

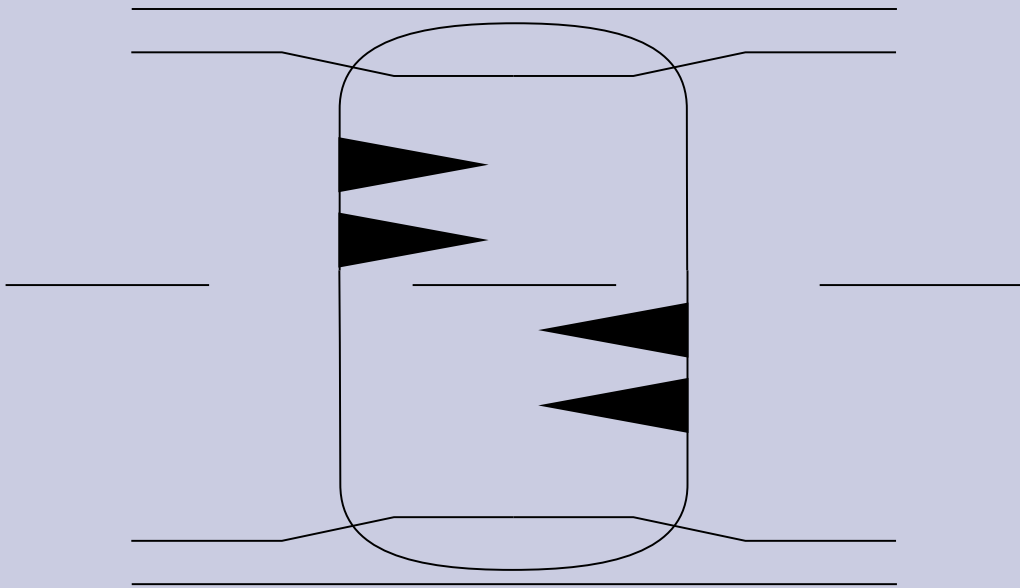

(Not To Scale)

Speed Tables

- 4.8 Speed tables raise the surface of the road by between 25mm and 75mm in order to reduce the speed of vehicles. They can only be constructed on roads with speed limits of 30mph or less. They are most commonly used on junctions to slow traffic before give way lines and to reduce the apparent importance of the junction. They cover the full area of the junction and they are therefore much bigger than road humps.

Public transport and other large vehicles can easily use speed tables. A cyclist approaching a speed table is faced with an upgrade and then a long flat surface before downgrade. Thus speed tables are more comfortable to use than road humps.

Details of speed table design are shown on page 34

Speed Table >>

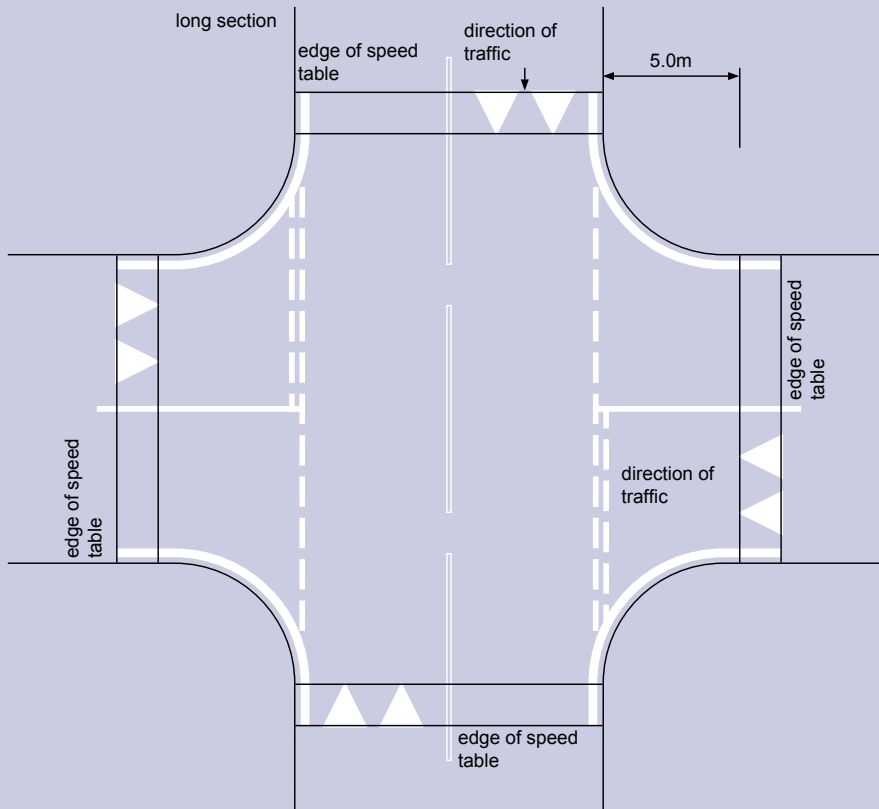
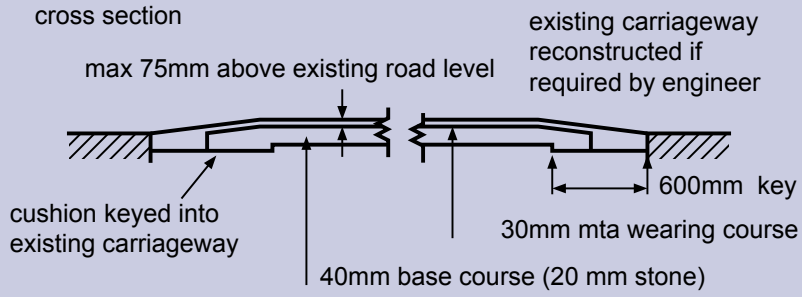
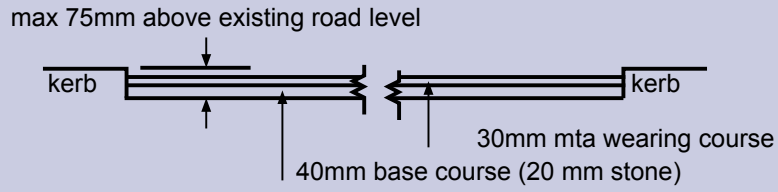

Redistribution of the Carriageway

- 4.9 On existing roads conditions for cyclists can be improved by the redistribution of carriageway space. On dual carriageways the alignment and width of the nearside running lane need to be considered.
- 4.10 Often this redistribution of the carriageway involves providing on highway cycle lanes. Cycle lanes on the highway can be either mandatory, where no vehicles are allowed or advisory, where they can overrun. Which type of lane is created depends on the circumstances, vehicle flows and vehicle mix, together with the width available.
- 4.11 The installation of lanes needs to be carefully considered as they can create situations where drivers of traffic travelling at speed, including heavy goods vehicles, perceive the cyclist to be contained within the lane and therefore drive close to the edge of it, thus creating a potentially more dangerous situation than if the cyclist was riding with the traffic on the carriageway and drivers were having to pull out to overtake them.
- 4.12 All cycle lanes must have the appropriate signing and cycle logos. They should have a green coloured surface, especially where they cross junctions. Where there is a long length of advisory cycle lane the green surfacing may not be necessary along the full length.
- 4.13 Mandatory lanes should be 1.5m wide, except in special circumstances where 1.2m is the absolute minimum acceptable (see Fig 5). Mandatory lanes should only be installed where a considerable length of unbroken lane can be created. Mandatory cycle lanes must be edged with a continuous white line, except across junctions where the line should become broken. Motor vehicles are not allowed to enter mandatory lanes. Drivers who stop in mandatory lanes can be fined.

[Contents >>](#)



left > right

Mandatory cycle lane.

Advisory cycle lane.

Bollard protection increasing safety on advisory cycle lane.

4.14 Advisory lanes should be at least 1.2m wide (see Fig 5) and edged with a broken white line. Motor vehicles can enter/cross them. Advisory lanes can be obstructed by parked vehicles unless Traffic Regulation Orders restrict parking/waiting.



4.15 Where cyclists have to climb steep inclines lane widths generally need to be increased.

4.16 Cycle lanes should extend to junctions and not end before them. In designing roundabouts and multi lane roads particular attention needs to be paid to the positioning of vehicle and cycle lanes. Where cycle lanes are proposed along side parking bays the lane must be advisory. A hatched buffer zone of at least 750 mm should be provided between the parking area and the new cycle lane. This helps overcome the problems of car doors opening onto cyclists.



Advanced Stop Lines

4.17 The Traffic Signs Regulations and General Directions (TSRGD) 2002 lay down a new regulation 43 which clarifies the meaning of “primary signal”, “secondary signal” and “stop line” in relation to light signals, including those at junctions where there are two stop lines. Regulation 43(2) specifies and clarifies the significance of each of the stop lines shown in the advanced cycle stop line layout prescribed in diagram 1001.2 in Schedule 6 of the Regulations so that it is consistent with the advice given in rule 154 of the current Highway Code. All Advance Stop lines and their feeder lanes must be surfaced in green.

top > bottom

cycle lane taken right up to a roundabout

advanced stop sign with mandatory feeder lane.

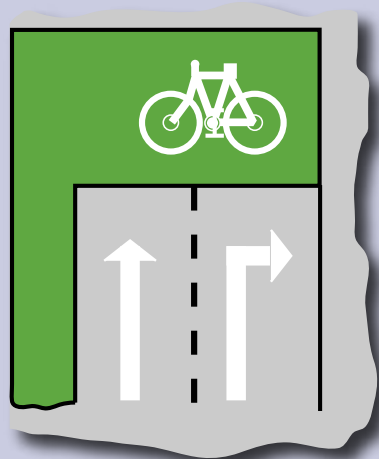

nearside approach lane and advanced stop line

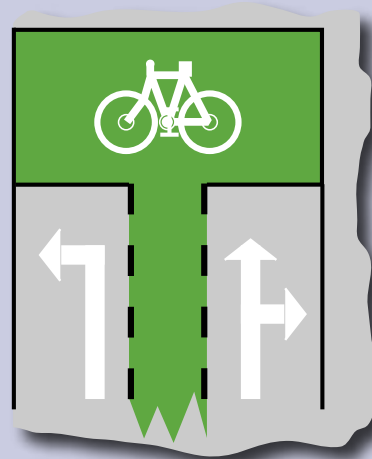

central approach lane and advanced stop line

Contents >>

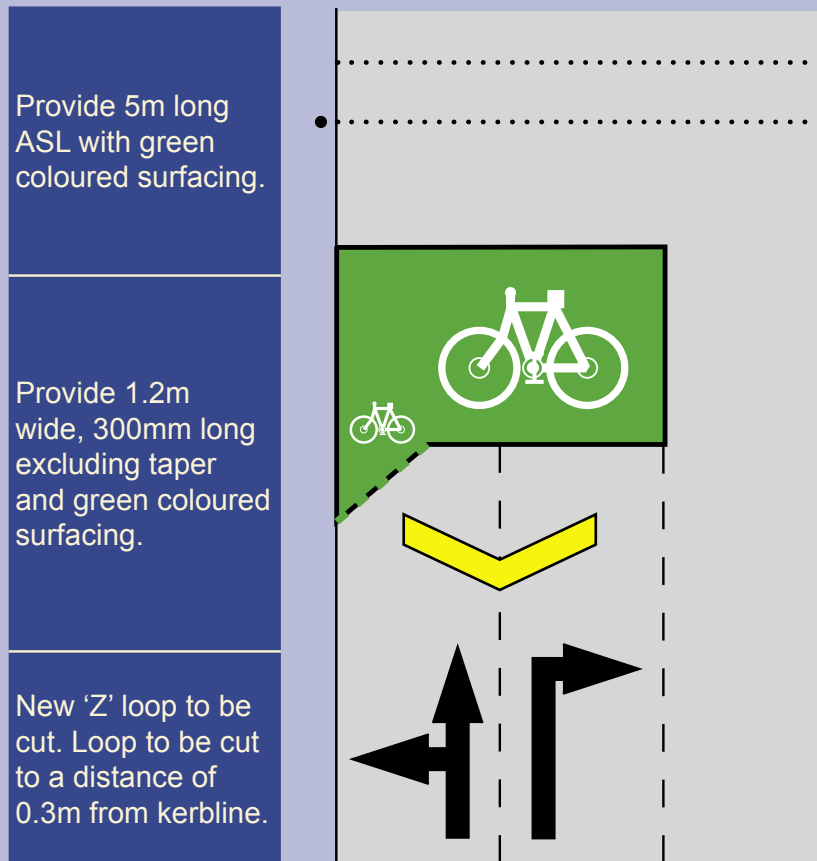

- 4.18 The Department for Transport Circular 02/2003 states that all advanced stop line layouts are required to have an approach lane, whether advisory or mandatory. If a red signal is showing, cyclists may only enter the reservoir ahead of the first stop line via the cycle approach lane, they may not do so by crossing the stop line. The approach lane needs to be of a size to allow cyclists to enter the reservoir without being obstructed by other vehicles. The appropriate length of approach lane can be established by assessing the average vehicle queue length at the junction. An advisory approach lane can be indicated by use of the markings to diagrams 1057 and 1004 or 1004.1, with or without an upright sign to diagram 967 of the TSRGD.

- 4.19 Direction 18(2) specifies that the advanced stop line marking to Diagram 1001.2 may be placed only at a signalled junction. It may not be used at level crossings or stand alone signal controlled crossings (for pedestrians, cyclists or equestrians) such as pelican crossings.
- 4.20 All new roads and existing roads which are being modified to include traffic lights as a requirement of a new development will be required to have advanced stop lines with appropriate length cycle feeder lanes.
- 4.21 At existing traffic light junctions feeder lanes will be required where there is sufficient existing roadspace for their provision. Where the approach lane is to be mandatory then it should ideally be 1.5m wide. In special cases where this cannot be achieved, but a mandatory lane is appropriate, then it should be no narrower than 1.2m wide. In the case of an advisory feeder lane then they should be 1.2m, with the absolute minimum width acceptable being 1m.
- 4.22 At existing traffic light junctions and where traffic lights are being introduced at existing junctions there may not be sufficient roadspace to create a standard feeder lane, either mandatory or advisory. In these cases the layout illustrated on page 37 is recommended.
- 4.23 Where there are wide pavements then an alternative arrangement could be considered. A cycle approach lane could be created with a slip off the road onto a segregated cycle route on the pavement and then back into the advance stop line.

4.24 The layout of feeder lanes should allow cyclists to enter the advanced stop line easily. They need to take account of the traffic lanes and in particular right and left turning movements.



top left >



Edinburgh

Two separate feeder lanes giving access to separate advanced stop lines at the end of a one way street.

top right >

Liverpool

Splayed advance stop lines.

bottom left >

Cambridge

Cycle lane splitting into two feeder lanes.

[Contents >>](#)

Roundabouts

4.25 Roundabouts in Britain are generally designed with splayed approach lanes which maximise the flow of traffic. Unfortunately this also maximises the speed of entry and in many cases the motorists ability to “straight-line” the roundabout. In addition the Highway Code advises drivers on approaching roundabouts to “adjust your speed and position to fit in with traffic conditions.” All this makes roundabouts very difficult for cyclists.



above >

Roundabout modified to a continental design to reduce traffic speeds. It has also had advisory cycle circulation lanes marked out to assist cyclists.

4.26 On the continent, roundabouts are designed with approach lanes which are more at right angles to the roundabout. This means that drivers have to approach at slower speeds and drive round the roundabout. A continental layout design is shown on the plan of an existing roundabout and shows just how much a layout may need modifying to reduce speeds and increase safety for cyclists.

4.27 Elsewhere these measures have already been implemented and linked to other improvements to guide cyclists through roundabouts and raise motorists' awareness of the presence of cyclists. Annular cycle lanes with coloured surfacing should be considered. Where these are inappropriate because of speed and approach lane alignment then cycle crossing of the junction arms should be installed. These crossings would ideally be signal controlled. In some cases wide subways, such as at Carters Green and Leabrook islands on the Black Country New Road, can assist in helping cyclists across major roundabouts.



Amendments to existing roundabout to reduce vehicle speeds, assisting cyclists while maintaining use for long vehicles and buses.

- 1 Existing refuge to be amended.
- 2 Junction amended to reduce entry and exit speeds and installation of pedestrian refuge with illuminated bollards and tactile paving.
- 3 Build out to reduce mouth of junction.
- 4 Amend existing island.

One-way streets

4.28 Prevention of two-way cycle traffic on one-way streets will inevitably lead to greater times and distances than would otherwise be the case for some cycle journeys. This unfortunately may also force cyclists to use busier roads.

4.29 One-way streets for motor traffic should, under normal circumstances always be available to cycle traffic in both directions. To enable this two way flow a contra-flow cycle lane should be established with appropriate markings and protection. Exemptions for cycle traffic should always be considered when one-way streets are promoted for general traffic management.

4.30 A lane, mandatory or advisory, should always be marked on the carriageway. The width of the contra-flow lane should be 2.0m. However wider lanes may need to be provided depending on the speed, volume, composition, visibility of oncoming traffic, and particularly where the lane is advisory. Narrower lanes will only be acceptable where traffic speeds are low and lorry flows very small. Protection is required for cyclists. This can be achieved by kerbing, repeater islands and bollards or hatching creating a buffer zone between the running lane and the centre flow.

4.31 Consideration also needs to be given to widening the lane on bends, such measures prevent encroachment by vehicles and increase the perception of safety for cyclists. Mandatory cycle lanes should be used where waiting and loading can be prohibited and where no encroachment by opposing direction vehicles is anticipated. Advisory cycle lanes should be used in all other cases. Where parking can be accommodated due to the width of the road the cycle lane should be set away from it by at least 750mm.

4.32 General advice on contra-flow cycle facilities is given in Transport Advisory Leaflet 6/98.

Signing

For full details on the signs used for cycle lanes etc, refer to; The Traffic Signs Regulations and General Directions 2002 Statutory Instrument 2002 No. 3223.



Cambridge
One-way cycle
contra-flow should
not end prior to
hazardous bend.

Cambridge
Contra- flow cycle
lane.

Leicester
Two Way cycle lane
on one-way street
going into two way
street with separate
cycle lane.

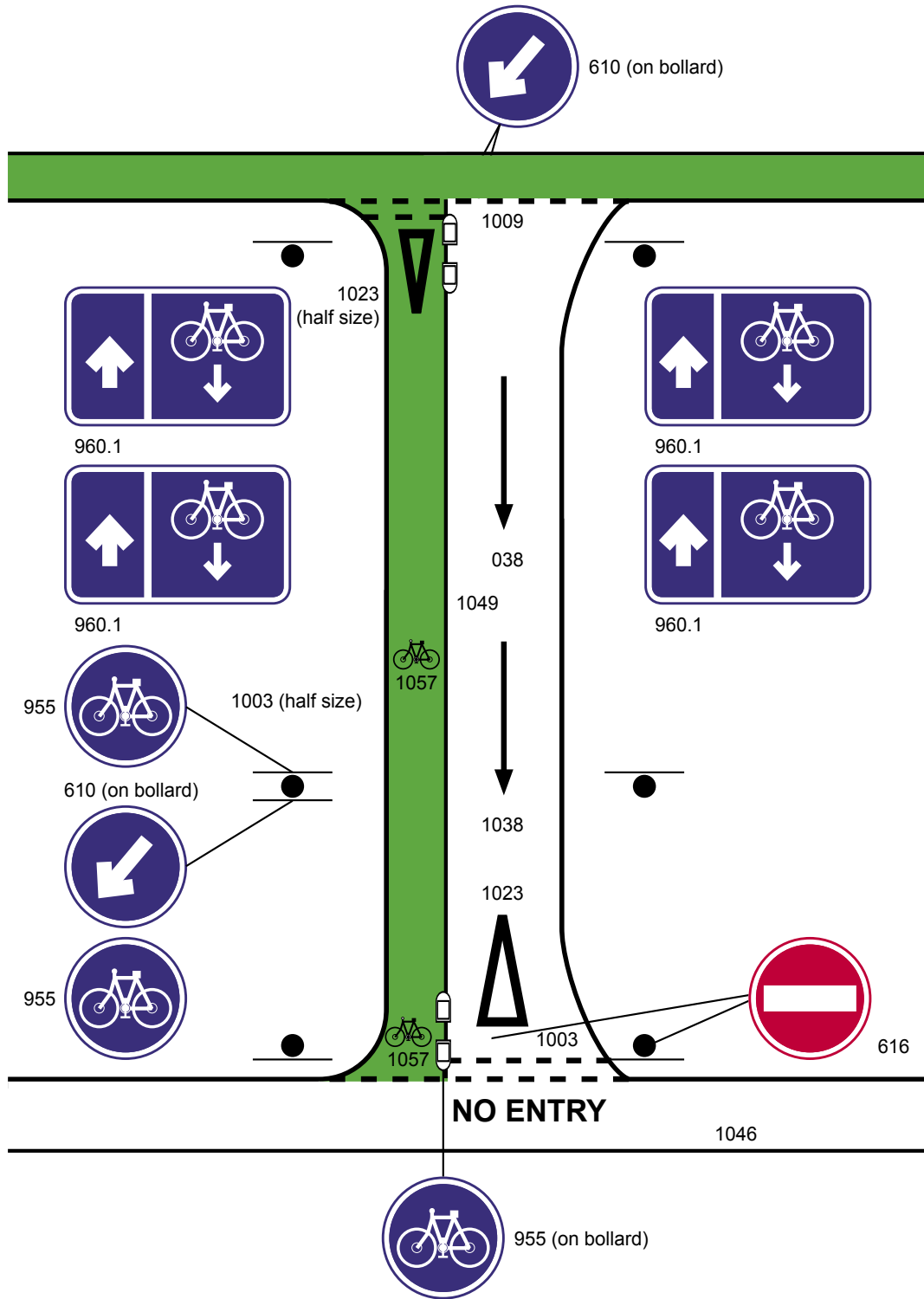

- 1 Width of cycle lane to be 2.0 metres, wider where necessary to help prevent over running e.g. at bends.
- 2 Additional island may be necessary on longer sections.

[Contents >>](#)

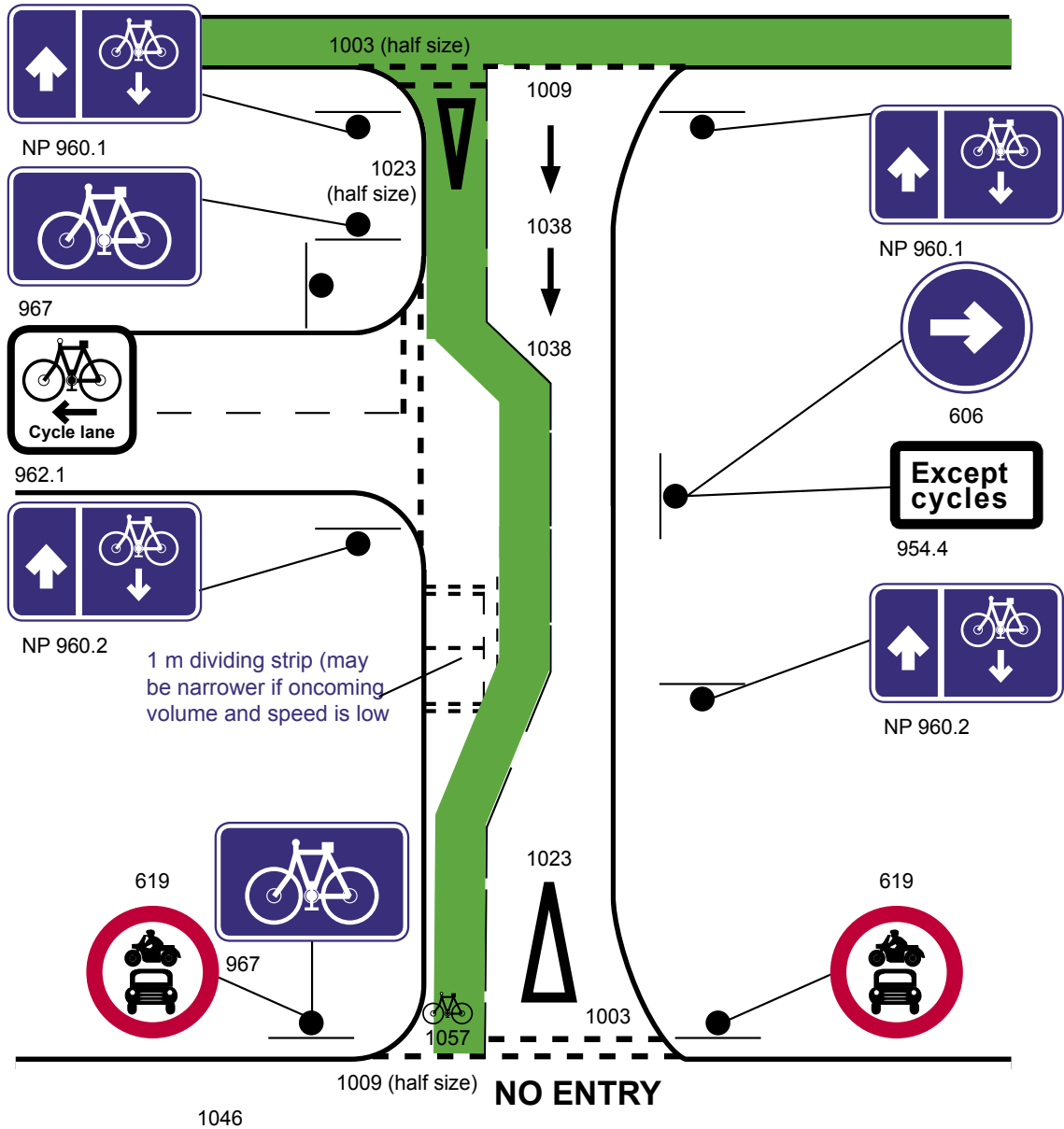

- 1 Width of cycle lane to be 2.0 metres, wider where necessary to help prevent over running e.g. at bends.
- 2 Additional island may be necessary on longer sections.

[Contents >>](#)

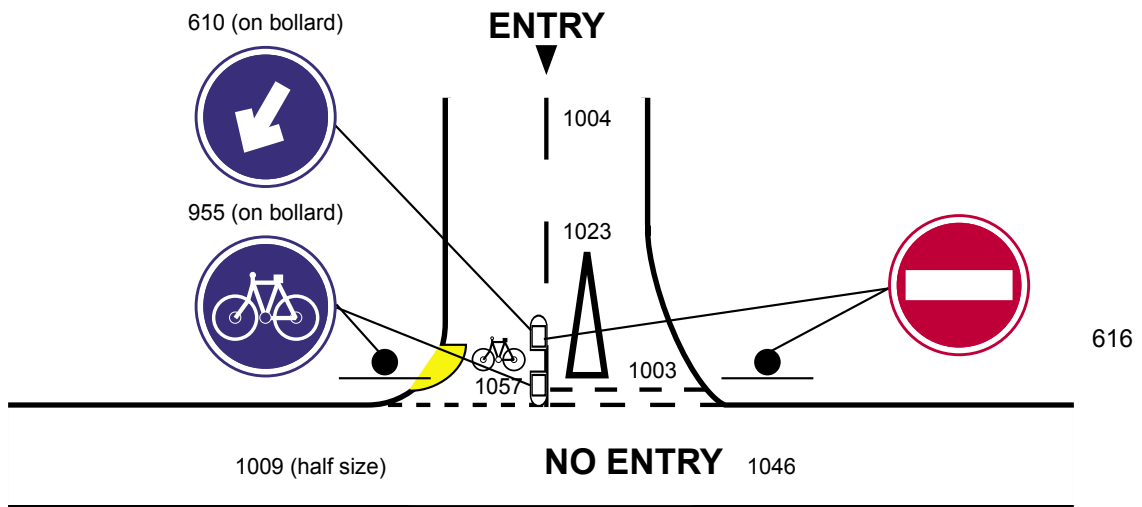

- 1 Kerb and white line changes should accommodate drainage and highway sweeping requirements.
- 2 The exit detail is relevant only where motor traffic does not join the false one-way street part way along.

[Contents >>](#)

Toucan Crossing

- 4.33 Toucan crossings are an unsegregated crossing for both pedestrians and cyclists which allow cyclists to legally ride across the crossing. Cyclists using zebra crossings and puffin crossings have to dismount and walk across the road in order to comply with the law.
- 4.34 Toucan crossings need to be accessed by pedestrians and cyclists and therefore there should be adjacent segregated or shared use facilities for these. In addition cyclists need to be able to access the Toucan from the road and also level it to rejoin the road. This will involve the construction of dropped kerbs and in some cases a jug handle segregated cycleway. Toucans were originally installed with opposite signals, but the installation of nearside aspect controls is now encouraged. Traffic Advisory Leaflets 10/93 and 4/98 provide detailed guidance on Toucans.

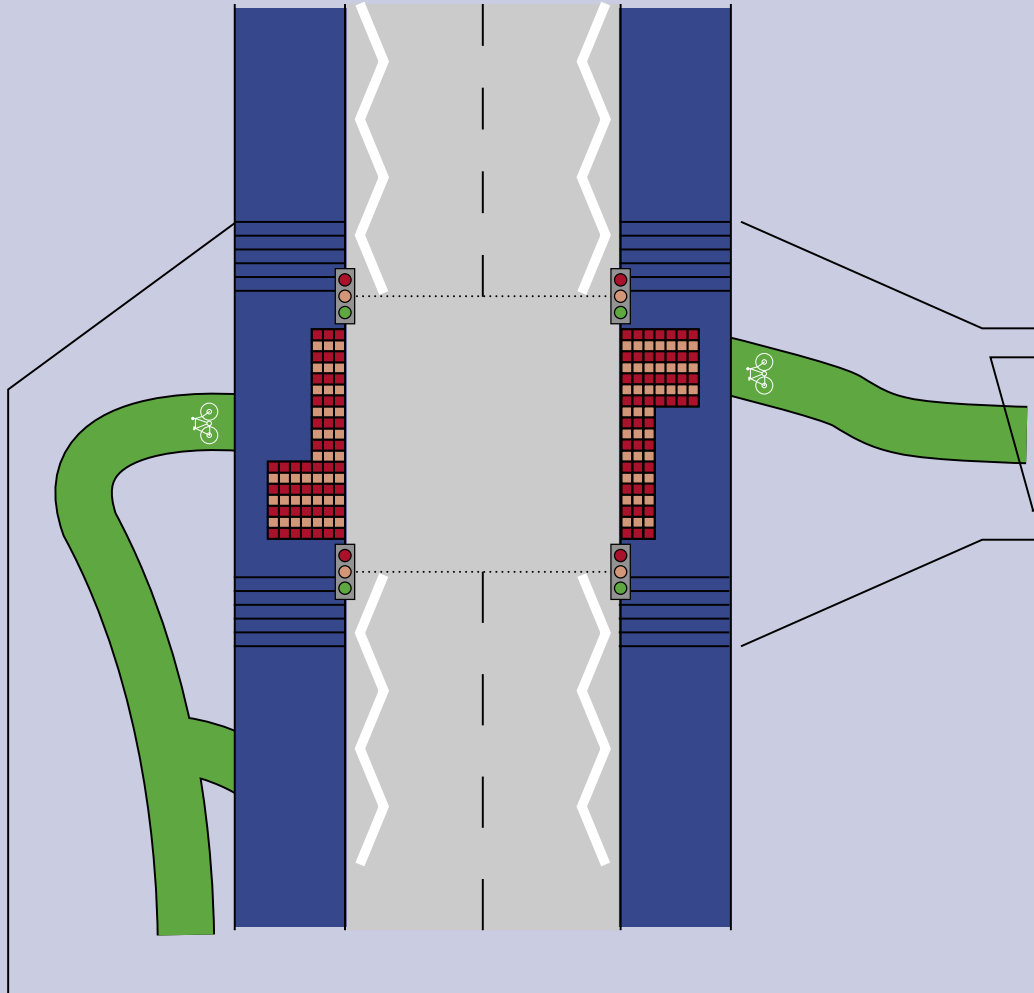

Problem features

- 4.35 There are many measures presently popular for addressing certain traffic issues that create problems for cyclists.
- 4.36 Build-outs of any sort deflect cycle traffic into the path of motor vehicles. Careful design can minimise the problem and adequate hatching and signing to warn cyclists and vehicle drivers of the hazard need to be planned in. Build-outs should not be positioned in such a way as to create a weaving route where cyclists have to go in and out of the main traffic flow.
- 4.37 The introduction of pedestrian refuges can assist in defining crossing points for pedestrians. These can cause problems for cyclists particularly as motor vehicles turn into the path of cyclists at refuges and sometimes race them for the gap or overtake too closely. Refuges should only be installed where there is demonstrable demand and/or a known accident problem. The following minimum width criteria should be met: 5.0m, 4.5m, 4.0m
- 4.38 Narrow cycle lanes (less than 1.5m) should never be used past a refuge, as they encourage drivers to drive dangerously near to cyclists in the gap. Ideally a cycle symbol should be placed in advance of the refuge to alert drivers to the likely presence of cyclists.
- 4.39 Left turn only lanes can be a particular problem for cyclists. The design of such facilities needs to be carefully considered. It is recommended that they are avoided where they are up hill.

Right turns

- 4.40 On roads where cyclists have to make a right turn, particularly into a cycle specific facility, a protected right turn may need to be provided on safety grounds. Ideally this should be in the form of road markings, a protected area for cyclists to stop in with bollard and kerb protection from oncoming vehicles. The facility should be clearly signed, including advanced cycle route signing to alert cyclists to the right turn and motorists to the likelihood of cyclists crossing the running lane. Where bollard and kerb protection cannot be provided then extensive hatching and cycle logos should be used.

Off-Road Cycle Routes

- 4.41 Off-road routes can be important for providing direct routes through heavily trafficked areas, linkages between housing areas and shops and other facilities and as leisure routes. They can also take advantage of other transport corridors. Sandwell has an extensive network of canal towpaths which provide good, level off-road routes. In addition the Metro route is paralleled by the West Bromwich Parkway. Off-road routes form an integral part of the proposed Sandwell Cycle Network. Opportunities for improvement of canal towpaths as part of new developments, the potential of new Metro routes and areas of open space need to be developed and must be considered in the planning of developments.
- 4.42 The Supplementary Planning Guidance on Community Safety should be consulted for guidance on the safe provision of routes. It notes that cycleways are important to encourage more active use and linkages of areas and should be located where they will be most utilised and provide a functional route between places. In addition the Sandwell Walking Strategy highlights important issues which need to be addressed when planning off-road routes.

[Contents >>](#)



Hierarchy of measures to improve off-road cycling

4.43 The hierarchy to be applied is:

Segregated cycleways

4.44 These should be provided at an adequate width to allow cyclists to pass in both directions. This would normally be at least 2.5m wide. Where walkers are also to be catered for by a parallel adjoining path then adequate additional provision must be made for them. Where the route uses a Bridleway, then not only will provision for walkers be necessary but also horse riders. In this latter case it will also be necessary to consider the most appropriate surface for each user.

Shared use cycleways

4.45 These should only be considered where segregated routes cannot be provided due to space constraints. They may be considered appropriate, where segregated provision would have a significant affect on the amenity, vegetation and appearance of the area, particularly where a wide route would be visually intrusive eg. (through open space, parks across agricultural land and on canal towpaths and Metro routes.)

4.46 Off-road cycle routes should avoid tight turns and steep gradients. Their siting needs to be carefully considered. The surrounding vegetation and landscaping needs to be chosen in order to prevent undue intrusion into the cycle route and problems of future maintenance. Trees and bushes, especially wild roses, are a problem if they are sited close to the cycleway and allowed to overhang it.

4.47 Off-road routes can be surfaced in a variety of materials. The surface chosen should be smooth to ride on and hard wearing, requiring minimum maintenance. It should be easily drained and not susceptible to rutting or ponding. Aesthetics may dictate that the surface eventually chosen should be appropriate for its surroundings. This will be very important in Conservation Areas and adjacent to Listed Buildings.

4.48 A standard specification for off-road cycle routes is shown in the diagram below. The edging can be either concrete kerb or treated timber boarding as this assists easier maintenance and discourages weed incursion more than simply laying a wider surface with no edging as promoted elsewhere eg. in more rural locations.

4.49 Off-road cycle routes in Sandwell have been surfaced in the following materials, all of which have been found to be successful and durable:

Tarmac – Sandwell Valley, West Bromwich Parkway and Victoria Park Tipton.

Breedon Gravel – canal towpaths

Black Ash – canal towpaths in Tipton

Colourpave – ramps off bridges down onto canal towpaths

Fibredeck – Walsall Canal and Sandwell Valley

Anti-skid – Galton Bridge ramp off Roebuck Lane, Smethwick onto the New Main Line canal towpath.

4.50 When choosing a surface it is also very important to consider its texture and abrasive characteristics. A rough or loose surface can do considerable damage to a cyclist who falls off their bike and such surfaces should be avoided.

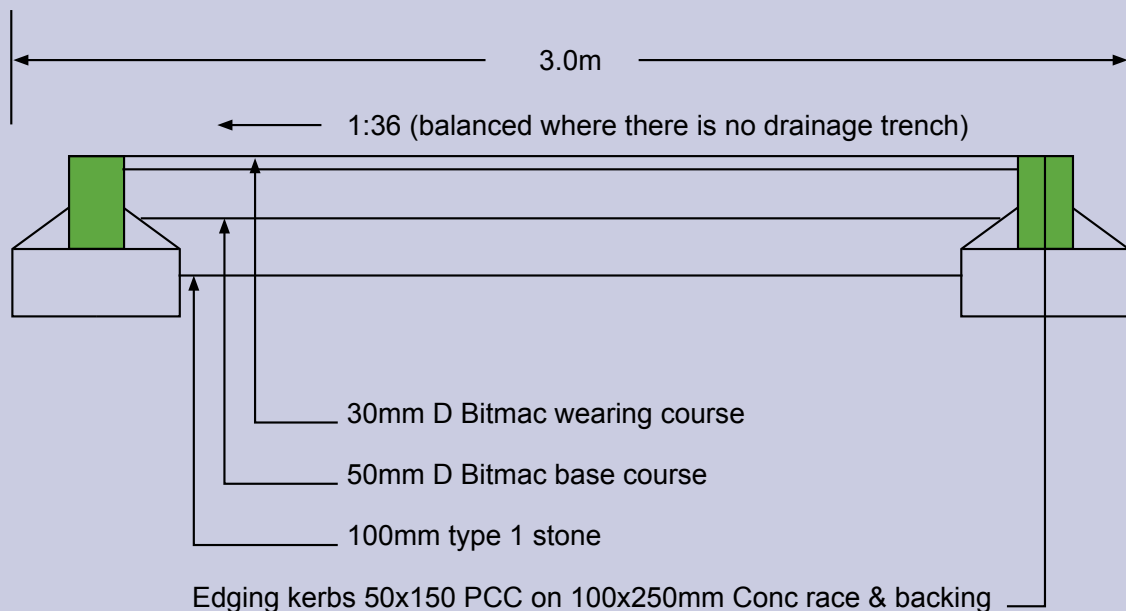

[Contents >>](#)

Legal and Planning Issues of Off-Road Routes

- 4.51 Off-Road cycle routes can be created in a number of ways: When a new development is planned it may require the inclusion of an off-road cycle route to protect a desire line or to create a direct route for cyclists out of a development which avoids a long journey following circuitous estate roads. The developer will usually dedicate the land and the cycle route may be adopted as a highway under Section 38 of the Highways Act 1980. The Highway Authority is willing to adopt a highway only if it has been constructed in accordance with this Supplementary Planning Guidance and the Highway Authority's specification. Lighting may be required. The advantage of this method of creation is that maintenance can be planned for and financial liability for it reverts to the Highway Authority.
- 4.52 Section 24 of the Highways Act 1980 empowers the Highway Authority to create a new highway. Bridleways and cycle tracks are highways and so can be created using Orders.
- 4.53 To convert all or part of a Public Right of Way footpath to a cycle track, a Footpath Conversion Order may be made under Section 3 of the Cycle Tracks Act 1984 and the Cycle Track Regulations 1984 (S1 1984/1431). If the footpath crosses agricultural land then the consent of those with legal interests in the land must be obtained for the conversion (S3(2)).
- 4.54 Objections may be received to a Cycle Tracks Act application and a Public Inquiry held. In such a case it is the Secretary of State for Transport who will confirm or otherwise the Order. Circular 1/86 Roads provides further detailed advice.
- 4.55 A footway to a highway in a new housing or industrial estate may co-exist with a definitive footpath that itself may have been diverted to allow for the layout of the new development. Legal advice needs to be sought in such circumstances as an Order to create a cycleway may be required.

4.56 Permissive routes are where the landowner allows cyclists to use a route across their land. Some may have public rights of way associated with them, however the vast majority do not have a legal status as a right of way and the landowner has no intention of allowing such a status to be created. Their use may require a licence, such as the free permit required by British Waterways for the use of all canal towpaths in Sandwell.

Measures to control speed and access

4.57 Chicane barriers can be useful for reducing cyclists speed on off-road cycle routes. Their use should be considered where off-road routes join the highway or where crossings of other routes occur, e.g. where the West Bromwich Parkway crosses the Metro. The chicanes should be designed and constructed to slow cyclists down and allow them to cycle through, rather than having to get off and walk.

4.58 Low hoops have also be used at the start of sections of off-road cycle route in Sandwell to allow cyclists through but prevent other vehicles from entering.

4.59 British Waterways may require barriers to be erected on canal towpaths to prevent abuse by motorcyclists and also to slow cyclists down. However these should only be installed where a definite problem exists. It should be recognised that barriers inhibit use and make routes less attractive and this reduces the natural policing of the route and may lead to increased vandalism and future maintenance problems.

4.60 In some cases these measures may be complementary and a route could exhibit examples of several of these categories and applications.

Cycle Parking Standards

- 5.1 Whilst the UDP has moved towards maximum parking standards for car parking for some classes of development as part of an approach to reduce the growth in the use of the car (see Policy T12), cycle parking standards will be minimum requirements in order to encourage cycling by providing sufficient secure facilities at destinations.

Generally cycle parking will be 1 cycle space for every 10 spaces provided for cars (based on the Council's maximum standards as expressed in UDP Policy T12 where there is a standard defined, not on the actual number provided.) There are a number of refinements and exceptions to this:

For employment uses, for example Offices, General Industry and Warehousing, of the spaces provided at least 75% should be in the form appropriate to staff parking, i.e. covered and high security such as lockers or enclosed stands.

For uses which attract a high number of visitors, such as retail, staff provision should be 33% of spaces provided.

For uses which are destinations for active users, such as leisure centres, indoor sports facilities, gyms, police stations and fire stations the requirement will be for 1 space per 6 cars

For transport interchanges not involving car parking, such as bus stations, high – security spaces should be provided at a rate of 1 stand per 2 bus services.

For residential development (other than where specifically provided for the elderly) cycle parking provision should be a minimum of one per unit with an additional space per 2 bedrooms. Where garages are provided these generally will be regarded as providing for cycles. For units which do not have garages, individual high security facilities will be required.

For Metro Stops and Stations Without Car Parks, provision will be based upon demand, although a minimum of 5 stands (ie 10 spaces) will be required. Proposals will be required to demonstrate how this demand and the level of security was determined and substantiate why, where it is proposed, the minimum is appropriate

For primary, secondary and special schools, staff spaces should be provided at a ratio of 1:60 pupils

For secondary schools, pupil spaces should be provided a ratio of 1:15 students

For further and higher education establishments, staff spaces should provided at 1 space per 50 students, and student spaces at 1 per 10 students

For schools and colleges all cycle parking should be high security (see page 59-60). Where a risk assessment is carried out, this should inform the type of secure facility provided.

[Contents >>](#)



middle right > bottom left
Essex, Sefton, Birmingham
Sandwell

Cycle Parking - Location and Design

Open Parking

- 5.2 Cycle parking available to all cyclists should be provided by facilities which are safe and secure to use and convenient to cyclists' destinations. Cyclists should be able to ride straight up to the facility and therefore dropped kerbs and/or ramps are an integral part of the provision. Stands should be sited so as to allow the bike to overhang either end. If more than one stand is to be sited at the same location, then the stands must be no less than 1 metre apart.
- 5.3 Where they are located by building facades, walls, fences or hedges, they should be at right angles or at an angle of no less than 60 degrees to them. The stand should be sited away from the facade or obstruction so that the bike can be properly supported by the stand and locked to it. (See photos)
- 5.4 In general public areas such as town centres, transport interchanges, health, leisure and community facilities, cycle parking should be positioned prominently where there are substantial flows of people, thereby providing surveillance and a deterrent to theft.
- 5.5 Where the parking serves a particular development it must be sited where it can be clearly seen and easily accessed and is adjacent to destinations. In the case of a retail or office park it is therefore appropriate for parking to be available at several locations within the site. For individual buildings it should be sited near the main entrance and directly accessible by cyclists. Sheffield stands should ideally be provided, subject to appropriate security (See page 56)
- 5.6 In Town Centres for general provision it is the policy of the Council to install stainless steel Penny Farthing cycle stands. These not only provide a secure facility for bikes to be locked to but also are an attractive piece of street furniture, enhancing the townscape and conveying a quality feel to the area.

left > Cycle sited too close to wall so bike is not supported properly and locking it securely is difficult, and the bike is prone to being knocked over.

right > properly sited cycle parking easily accessed from road.

Contents >>



Sheffield Stand

- 5.7 A typical Sheffield Stand layout is shown below. The stand provides good support to the cycle and allows the cyclist to secure both the frame and wheels without risk or damage. It should be constructed in stainless steel, preferably with a brushed finish.
- 5.8 Stands should be 750mm high and a minimum of 700mm long. A minimum distance of 1000mm should be provided between stands to accommodate two cycles per stand. Stand ends should either be embedded in concrete, bolted to the ground or welded to parallel bars at ground level to form a toast rack system. A minimum space of 500mm should be provided at either end of the stand where near an obstruction to enable cycles to be secured properly and easily removed.

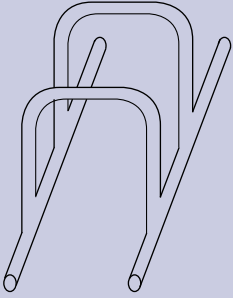

Linked "toast rack" stands for surface mounting in difficult locations e.g. surrounding services

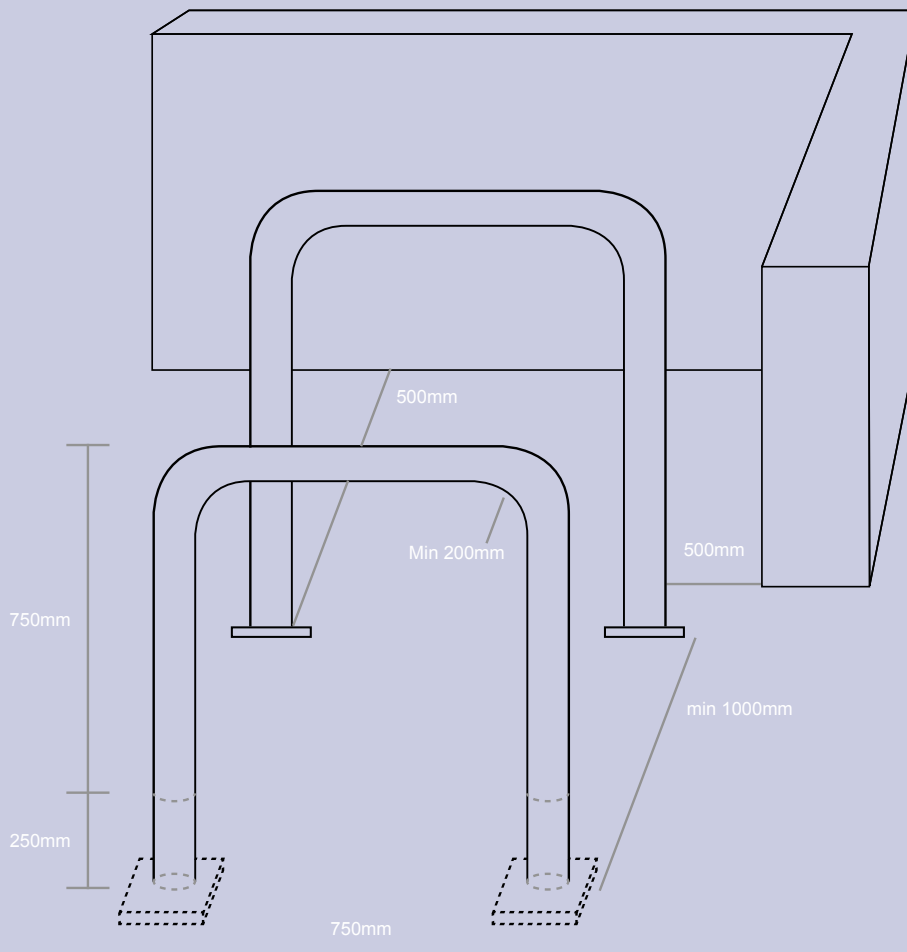

- 5.9 A standard design of cycle stand has been developed for all shopping centres in Sandwell. This is known as the Penny Farthing cycle stand. It can be also be used wherever an attractive piece of street furniture is needed.

[Contents >>](#)

Contents >>

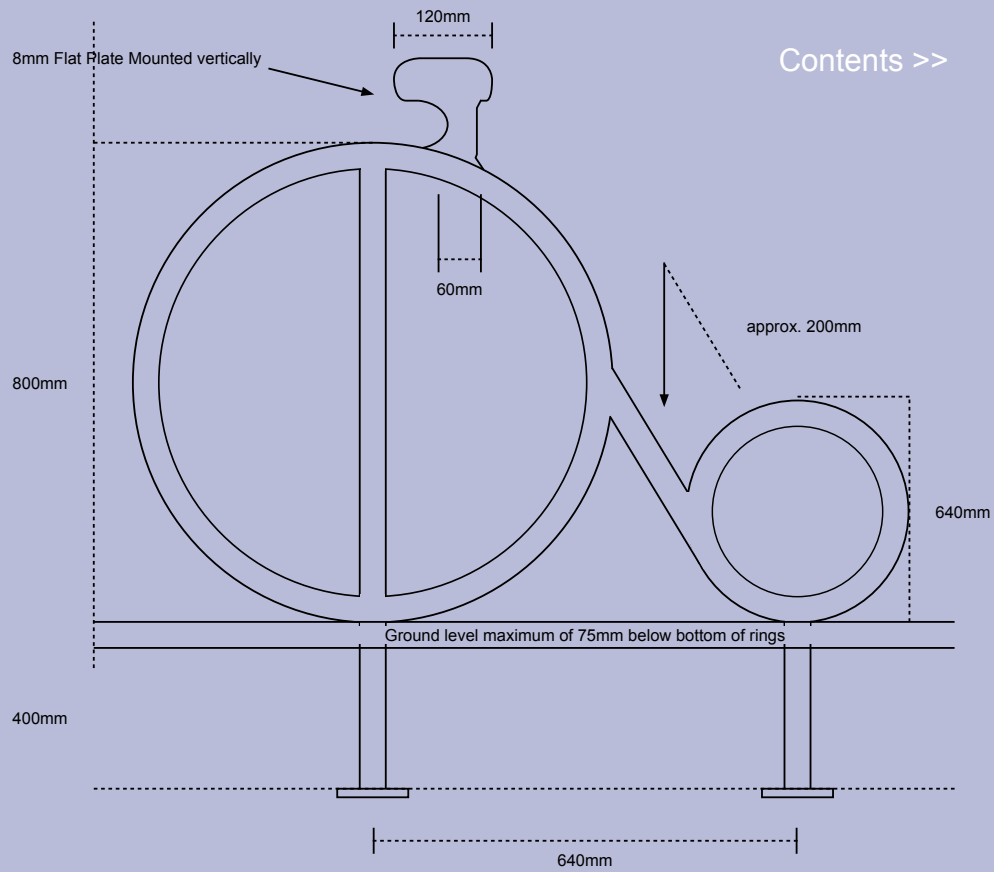

5.10 Where more than one is to be provided the stands must be a minimum of 1000mm apart.

5.11 Other types of cycle parking are available and the following photos gives a quick guide to those which are and are not acceptable for individual developments.

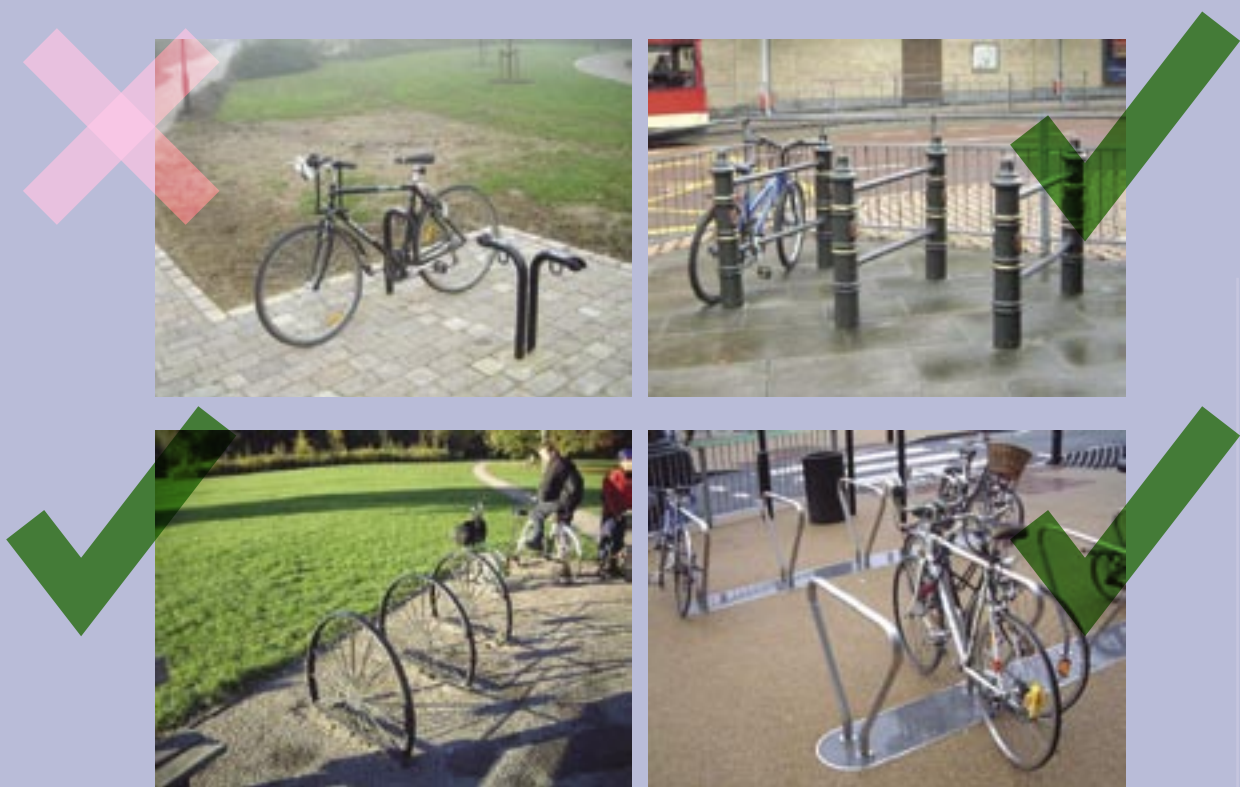

left > right > **Cambridge**. Cycle parking likely to damage bike. **Nottingham**. Parking suitable for a historic area. **Powys**. Cycle parking as public art. **Lambeth**. Cycle parking with a quality feel.

Enclosed Cycle Parking.

- 5.12 This is potentially the most secure and therefore attractive form of cycle parking. It can be created by installing lockers, converting part of a building or building new.
- 5.13 Where lockers are proposed their design and siting need to be carefully considered to discourage vandalism, abuse and theft. Lockers at railway stations must comply with the guidance on security and have an appropriate management system. Where enclosed parking is provided the inclusion of other facilities, such as changing rooms and showers should be considered. (see below)

Covered Cycle Parking.

Covered parking provides a very attractive facility. Good examples are illustrated below.





Secure Cycle Parking

- 5.14 Concern over security is a major deterrent to growth in cycling. Cyclists need to feel their bikes are secure and thieves need to be deterred. It is expected that all cycle parking or storage should enable a good level of security in line with national best practice.
- 5.15 The stands discussed above, if installed correctly, will enable a bike to be locked through both frame and wheels. This will often be sufficient for when and where a bike is left for a short period of time, e.g. a short shopping trip.
- 5.16 However where a cycle will be left for a longer period it is understandable that cyclists will require a high level of security or they will be discouraged from leaving what is often an expensive item.
- 5.17 A higher degree of security can be achieved by cycle sheds with lockable doors, or stands enclosed by a security cage. Access can be by key, swipe card or keycode. These are particularly useful for private parking, i.e. places of work or facilities with a membership, e.g. gymnasiums.
- 5.18 Individual lockers provide a high level of security for cycles and associated accessories such as helmets and are particularly suitable for situations where cycles are left for an extended period in a public place, such as at stations.
- 5.19 Cyclists will still wish to lock their machines even in such situations and this should be facilitated.

- 5.20 Properly managed and monitored Close Circuit Television surveillance can add to the security of cycle parking and consideration should be given to its integration into workplace or public systems. Staff oversight and the creation or maintenance of “natural surveillance” of the cycle park will also contribute to a more safe and secure environment.
- 5.21 For domestic properties garages can provide for secure storage. Sheds, especially wooden ones, however are generally insufficient. Where there are no garages provided in a residential development it is essential that secure storage is facilitated, preferably within the fabric of a building, although external cycle stores can provide sufficient security if well located, constructed and lockable. For flatted development or apartments it is unreasonable to require cyclists to carry their bicycles up flights of stairs regularly.

Contra Flow Cycle Lanes

These are cycle lanes which run in the opposite direction to the general traffic flow.

Coronary Heart Disease

Coronary Heart disease is caused by narrowing of the coronary arteries that feed the heart. An inactive lifestyle is a major risk in developing the disease. Regular, moderate-to-vigorous physical activity helps prevent heart and blood vessel disease.

CROW nomogram

A graphical method of identifying the appropriate cycle provision given certain road conditions. From the Dutch Cycle MasterPlan.

Legibility

A term used to mean the understanding of places. People are more comfortable with an environment which is easily understood, or “read”.

Section 106 Agreements

These are legal agreements, usually between the Council and the developer, which secure actions which are required to make a development acceptable in planning terms, e.g. the provision of off - site infrastructure to enable satisfactory access to the site.

Segregated Cycle Provision

This is where the cycle lane is physically separate from the other facilities, such as footpaths and roads.

Supplementary Planning Guidance (SPG)

Additional detailed guidance developing from the policies contained in the UDP. Planning applications will be expected to reflect the contents of an SPG.

Traffic Advisory Leaflets

These are leaflets relating to traffic and transport matters produced by the Department for Transport.

Travel Plan

This is a document prepared by an employer which enables and encourages staff to travel to and from their place of work in a sustainable manner, e.g. by foot, cycle, metro or train.

Unitary Development Plan (UDP)

The statutory land use development plan for the Borough. All planning applications will be required to be consistent with the policies and proposals within the document.

Useful Contacts >>**Sandwell MBC**

Sandwell MBC Web Site – www.sandwell.gov.uk

Planning Policy

Laurence Jackson 0121 569 4024

Laurence_Jackson@sandwell.gov.uk

Transportation Planning

John McIlroy 0121 569 4021

John_McIlroy@sandwell.gov.uk

TravelWise/Travel Plan Officer

Andy Thorpe 0121 569 4261

Andy_Thorpe@sandwell.gov.uk

Primary Health Trusts**Cycling and Walking for Health Development Officer**

Dene Stevens 0121 500 1660

Dene.stevens@nut-pet.nhs.uk

[Contents >>](#)

Other Documents >>

[The Community Strategy](#)
The Sandwell Plan, Sandwell MBC

[Local Agenda 21 Strategy](#)

[The National Cycling Strategy](#)
www.nationalcyclingstrategy.org.uk

[The Sandwell Cycling Strategy](#)
Cycling in Sandwell

[Sandwell Unitary Development Plan \(2004\)](#)
Sandwell MBC

[Supplementary Planning Guidance](#)
Community Safety, Sandwell MBC

[Supplementary Planning Guidance](#)
Design Guidance for Residential Areas, Sandwell MBC

[The Walking Strategy](#)
Sandwell MBC

[West Midlands Local Transport Plan](#)
West Midlands Joint Committee

[Traffic Advisory Leaflets](#)
Department for Transport
These can be found on the Department for Transport web site: www.dft.gov.uk
